

**Glass Passivated Bridge Rectifiers**  
**Reverse Voltage 50 to 1000 Volts Forward Current 3.0 Amperes**

**Features**

- Glass passivated junction
- Superior thermal chip junctions
- Plastic package has Underwriters Laboratory Flammability Classification 94V-0
- High current capacity with small package

**Marking**

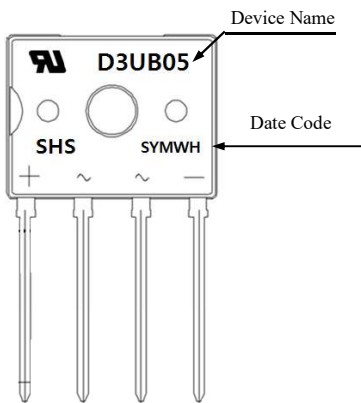

**Equivalent Circuit**

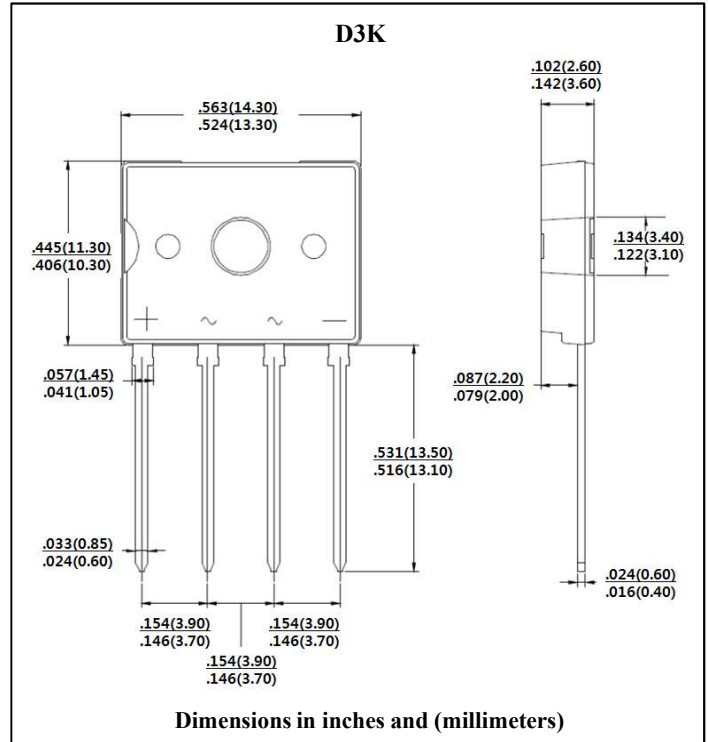
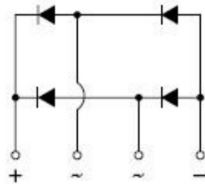

**Maximum Ratings & Electrical Characteristics**

Ratings at 25°C ambient temperature unless otherwise specified  
Single phase half wave 60 Hz, resistive or inductive load  
For capacitive load, derate current by 20%

Parameter	Symbol	D3U B05	D3UB 10	D3U B20	D3U B40	D3U B60	D3U B80	D3U B100	Unit	Remark
Maximum Repetitive Peak Reverse Voltage	$V_{RRM}$	50	100	200	400	600	800	1000	V	
Maximum RMS Voltage	$V_{RMS}$	35	70	140	280	420	560	700	V	
Maximum DC Blocking Voltage	$V_{DC}$	50	100	200	400	600	800	1000	V	
Average Rectified Output Current (60Hz Sine Wave, R-load)	$I_O$	3.0							A	Note 1
		3.0							A	Note 2
Peak Forward Surge Current 8.3 ms Single Half Sine-wave Superimposed on Rated Load (JEDEC Method)	$I_{FSM}$	70							A	
Maximum Instantaneous Forward Voltage @ 3.0A	$V_F$	1.1							V	
Maximum DC Reverse Current at Rated DC Blocking Voltage	$I_R$	5.0							uA	Ta=25°C
		500							uA	Ta=125°C
Rating For Fusing (t<8.3ms)	$I^2t$	20							A <sup>2</sup> S	
Typical Thermal Resistance	Rth(j-c)	1.5							°C/W	
	Rth(j-a)	40								
	Rth(j-l)	8								
Operating Temperature Range	$T_J$	-55 to +150							°C	
Storage Temperature Range	$T_{STG}$	-55 to +150							°C	

Note 1. Unit case mounted on 1.6\*1.6\*0.06"thick (5.1\*5.1\*0.15cm) Al plate

Note 2. Unit mounted on P.C.B. with 0.5\*0.5"(1.27\*1.27mm)copper pads and 0.375" (9.5mm) lead length

**Ratings and Characteristics Curves (Ta=25°C unless otherwise noted)**

**Fig.1 Forward Current Derating Curve**

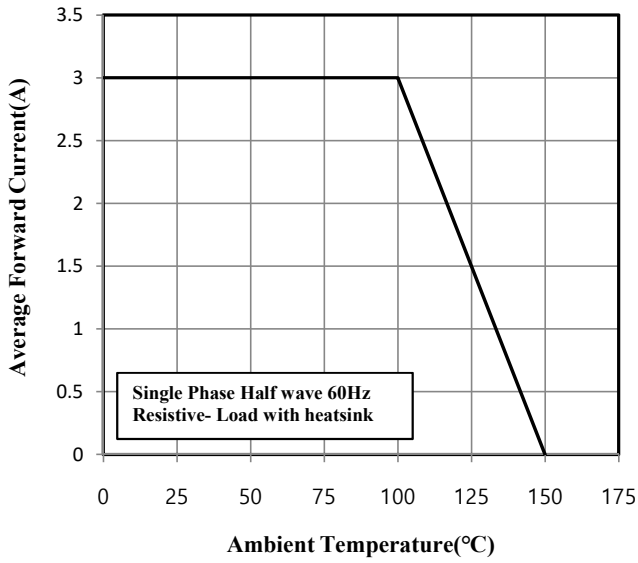

**Fig.2 Maximum Non-Repetitive Peak Forward Surge Current Per Bridge Element**

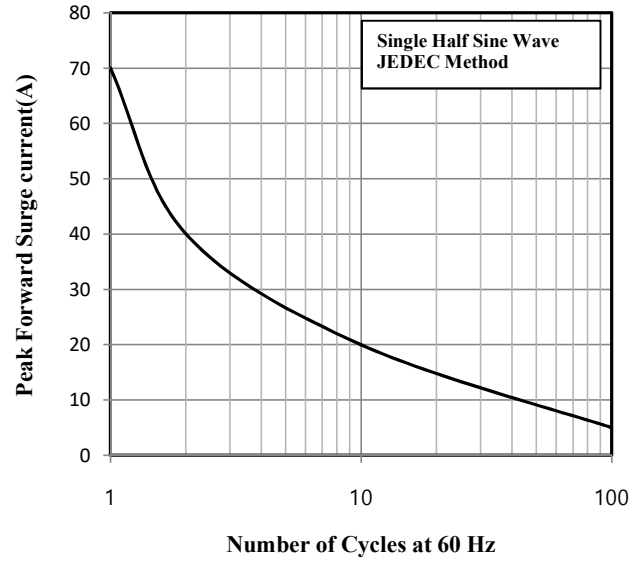

**Fig.3 Typical Instantaneous Forward Characteristics Per Bridge Element**

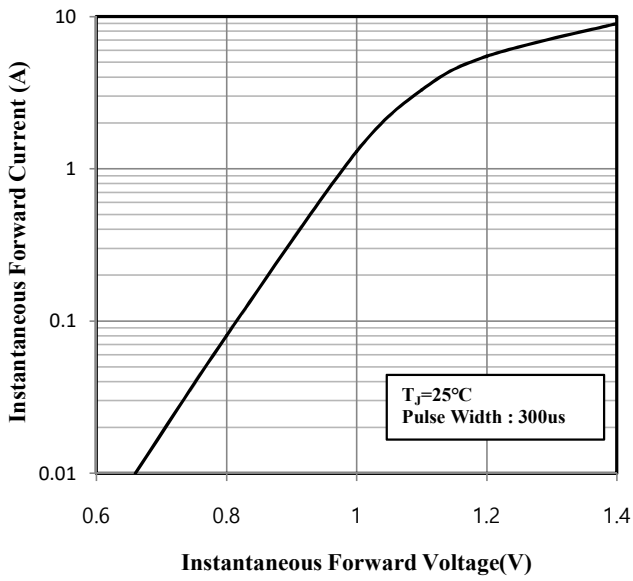

**Fig.4 Typical Reverse Characteristics**

